

VIPRA aim™

**Turnkey large format additive manufacturing
platform for metal deposition**

CARACOL

BUILD BEYOND POSSIBLE

Caracol is a global leader in robotic large format additive manufacturing technologies. Since 2015, our founders pursued the idea of pushing the limits of AM and existing manufacturing technologies beyond what was possible, combining innovation with an industrial vision to respond to client's production needs.

Placing users at the center, Caracol delivers integrated turnkey robotic solutions leveraging additive manufacturing, to provide simpler processes, flexibility, efficiency, sustainability, and enable customers' production continuity.

Index

Vipra AM - Introduction	4
Vipra AM - Models & Core elements	6
Models: XP and XQ	8
Eidos Manufacturing Software suite	10
Enclosure	11
Sensors	12
Robotics	12
Materials	14
Case studies	18
Aerospace	19
Marine	21
Oil & Gas	22
Industrial Machinery	23
Services	25

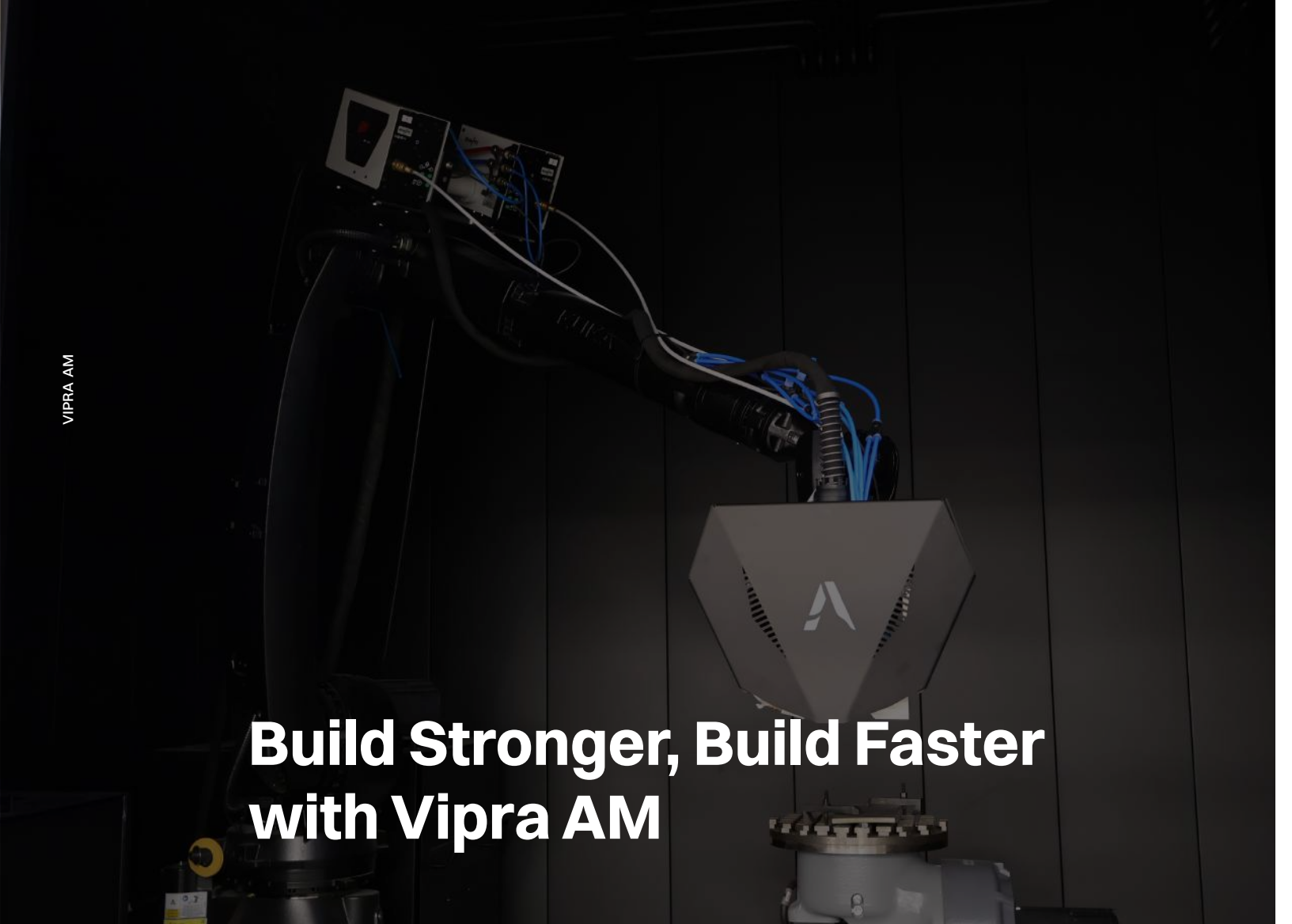

Build Stronger, Build Faster with Vipra AM

The integrated platform
that will drive you to the
next manufacturing revolution

Caracol created Vipra AM to evolve the possibilities of Additive Manufacturing on scale, shape, and materials, bringing its know-how on robotic LFAM to metals.

Vipra AM is Caracol's Robotic Large-Format Additive Manufacturing platform – an adaptive metal robotic 3D printer, for large scale, industrial applications.

Vipra AM is the one of the metal LFAM platforms that best integrates hardware, software, and automation: providing clients with a turnkey solution to **maximize flexibility, process control, and performance**. As one provider, Caracol delivers quicker innovation, higher customization, and prompt and reliable support.

Application-first

With its DNA in industrial production of large-scale parts, Caracol perfected Vipra AM with end-user's needs in mind, following years of research and experience manufacturing parts for clients across sectors.

Caracol's aim is to ensure clients' production quality and continuity for the most advanced applications. This is done by providing reliable technology, sharing know-how and the teams' expertise, and an extensive set of services to help clients leverage the full potential of their machines across applications.

The system is designed to manufacture complex, high-performance parts such as molds, propellers, flanges, pipe fittings, pressure vessels; replacement or enhancement for casted and forged components as well as repair high-value components.

Today Vipra AM has been chosen to operate in factories that meet the highest standards for production, with the most demanding industrial requirements and quality criteria.

Robotic Turnkey Platform

Vipra AM is a turnkey platform for advanced industrial production. Two deposition heads were developed to meet different production goals.

- 1 DEPOSITION HEAD
- 2 SENSORS
- 3 EIDOS MANUFACTURING SOFTWARE SUITE
- 4 FUME EXTRACTOR
- 5 ROBOTIC ARM
- 6 EXTERNAL MANIPULATOR
- 7 WELDING POWER SOURCE
- 8 CONTROL CABINET
- 9 LINEAR TRACK

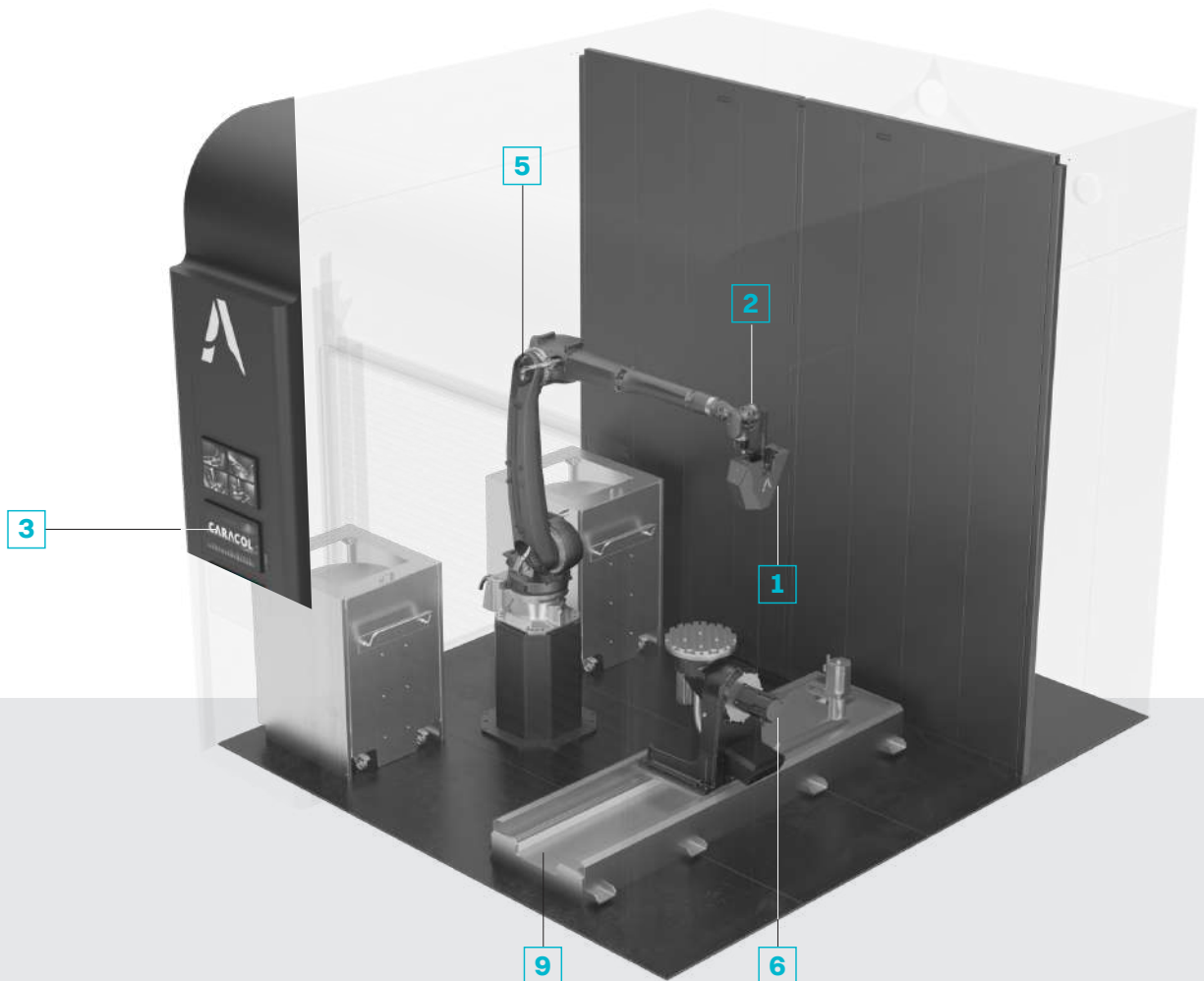

Vipra AM was developed to deliver a set of key benefits to users:

- **QUALITY**
made to build high-strength, high-integrity parts that meet the demanding specifications of advanced industries
- **EFFICIENCY**
drastically cut lead times (up to 90/95% vs traditional forging or casting) and lower costs
- **SUSTAINABILITY**
cutting material used and waste significantly, achieving buy-to-fly ratios as high as 90%, and lowering the overall impact of production
- **FLEXIBILITY**
allowing high degree of customization in design and geometries, printing on-demand complex parts, eliminating needs for large stock

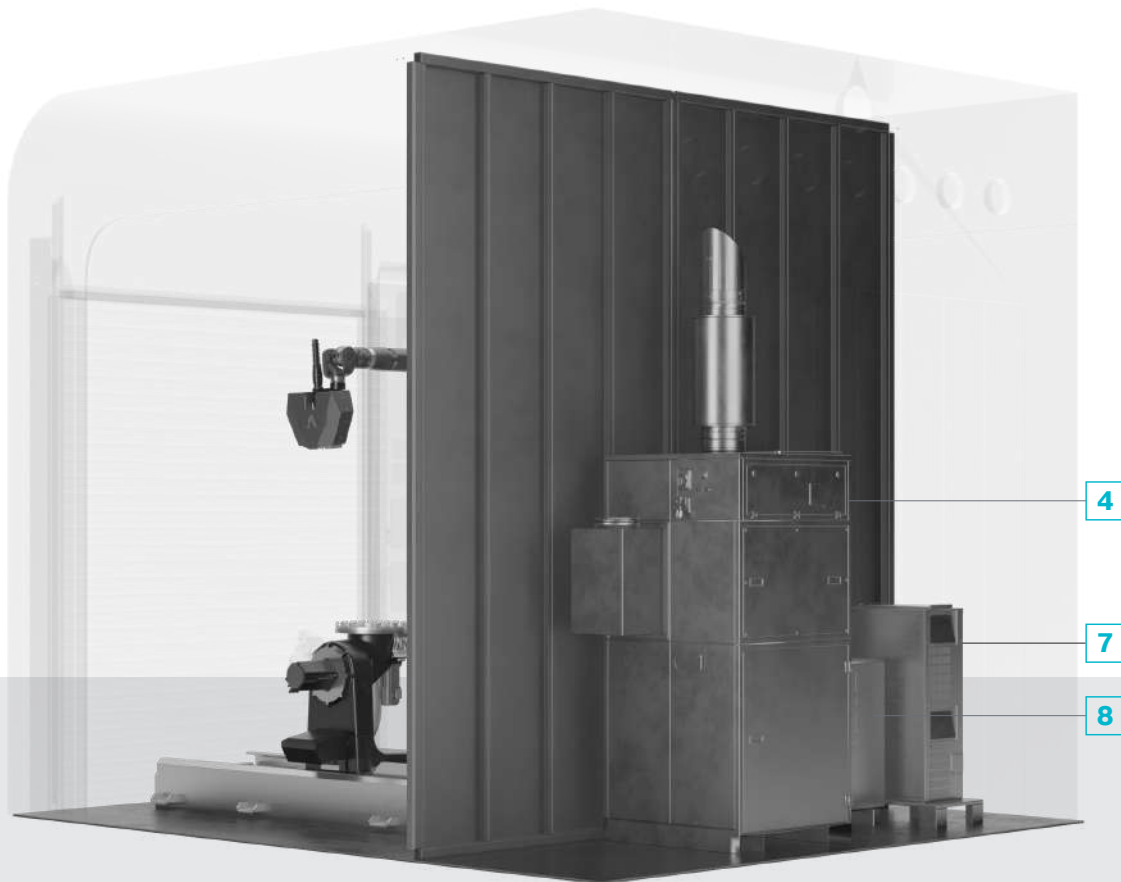

XP Extreme Productivity

The XP model uses CMT (Cold Metal Transfer) technology, to maximize productivity and process efficiency, and minimize operating costs.

This transformative process in Wire Arc Additive Manufacturing (WAAM) integrates advanced welding techniques with good process control for the efficient, layer-by-layer production of metal structures. CMT operates with a low-heat input, intermittently feeding the wire into the molten pool through a synchronized short-circuiting arc, ensuring both accuracy and efficiency.

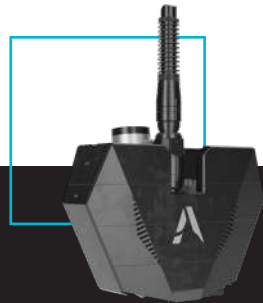

Benefits

- Maximized output and minimized costs, for enhanced productivity and reduced lead times.
- Low-heat to preserve material integrity, reduces distortions, and guarantees part mechanical strength.
- Clean, precise deposition with minimal spatter for consistent high-quality prints.

Applications

The XP model is ideal for producing large-scale parts across various industries, including aerospace, automotive, architecture, and railways. It is particularly well-suited for spare parts production, repair work, cladding, and tooling, offering the flexibility and performance needed for demanding industrial applications.

XP

Build Volume [m ft]	2.5 x 2.0 x 2.0 8.2 x 6.6 x 6.6
Enclosure Footprint [m ft]	4.2 x 5.1 x 4.3 13.8 x 16.7 x 14.1
Power Source	CMT - Cold Metal Transfer
Head Dimensions [mm in]	250 x 250 x 300 9.8 x 9.8 x 11.8
Weight of the Head [kg lb]	15 33
Anti-collision System	Yes
Monitoring System	Yes
Safety System, Level	Yes, High
Operating Current [A]	3 - 400
Operational Gas	Ar and Ar mixtures
Materials Compatibility, examples	Steels, Stainless Steels, Aluminium alloys, Nickel alloys, Copper alloys
Wire Diameter Size [mm in]	0.8 - 1.6 0.03 - 0.06
Wire Feed Speed [m/min ipm]	1.0 - 15.0 39 - 590
Max Deposition Rate [kg/h lb/h] measured through a standardized qualification procedure printing with SS316	6.0 11.0
Layer Height [mm in]	1.0 - 2.5 0.04 - 0.04
Positioner Payload [kg lb] - extendable	750 1650

XQ Extreme Quality

The XQ model leverages PAD (Plasma Arc Deposition) technology, to produce extremely high-quality components with exceptional finishing and precision.

It leverages a cutting-edge process in Wire Arc Additive Manufacturing (WAAM), which uses a Plasma arc to achieve precise, high-quality, high-speed metal deposition. This technology generates a concentrated plasma jet to melt the feedstock wire, which is then precisely deposited layer by layer onto a substrate, ensuring superior build quality and speed.

VIPRA AM

Limited Release

Part of our ongoing R&D program, this model is available in a limited release for pilot applications and performance evaluation.

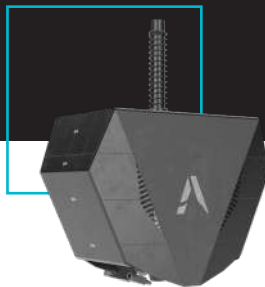

Benefits

- Extremely precise deposition, for smooth, high-quality surface finish, durable & mechanically robust parts.
- Processes a very wide range of weldable alloys, including high-temp materials like titanium and niobium.
- Concentrated heat for rapid melting and deposition means good build times and precise control.

Applications

This process is ideal for producing large-scale, high-strength industrial parts that require exceptional structural integrity, including components with thick walls, heavy sections, and complex geometries. It is perfectly suited for manufacturing demanding parts with excellent mechanical properties, making it a top choice for industries such as aerospace, energy, construction, and shipbuilding.

XQ

Build Volume [m ft]	2.5 x 2.0 x 2.0 8.2 x 6.6 x 6.6
Enclosure Footprint [m ft]	4.2 x 5.1 x 4.3 13.8 x 16.7 x 14.1
Power Source	PAD - Plasma Arc Deposition
Head Dimensions [mm in]	250 x 250 x 300 9.8 x 9.8 x 11.8
Weight of the Head [kg lb]	15 33
Anti-collision System	Yes
Monitoring System	Yes
Safety System, Level	Yes, High
Operating Current [A]	5 - 350
Operational Gas	Ar
Materials Compatibility, examples	Steels, Stainless Steels, Nickel alloys, Copper alloys, Titanium alloys, Niobium alloys
Wire Diameter Size [mm in]	0.8 - 1.6 0.03 - 0.06
Wire Feed Speed [m/min ipm]	1.0 - 10.0 39-390
Max Deposition Rate [kg/h lb/h] measured through a standardized qualification procedure printing with SS316	3.0 6.6
Layer Height [mm in]	0.8 - 2.0 0.03 - 0.08
Positioner Payload [kg lb] - extendable	750 1650

CARACOL

Eidos Manufacturing Software suite

Caracol developed its software suite Eidos Manufacturing after years working on LFAM, slicing strategies, and robotic cinematics. The suite completes Vipra AM's platform to provide full control and flexibility.

VIPRA AM



Builder

Seamlessly develop the slicing and set your printing parameters with a user-friendly interface. Visualize real time your robotic platform to simulate prints and choose your printing approach: from planar to revolved or radial, enjoy full control and accuracy on your slicing to work on complex tool paths and setting your production parameters.



Monitoring

Guaranteeing quality and repeatability entails having a data-driven approach, learning from every print to constantly improve production.

Vipra's monitoring suite was designed to collect and display sensor data in conjunction with robot's position, creating a real time digital twin of the process. This smart monitoring system ensures full visibility over machine performance, enabling you to track quality and maintain detailed records for every print. By continuously analyzing sensor data and machine feedback, this software helps guarantee consistent results and aids in optimizing production processes.

CARACOL

Enclosure

Caracol developed an advanced enclosure for Vipra AM. Engineered to ensure the optimal production space by combining advanced safety features, environmental control, and seamless integration with the platform.



VIPRA AM

Fume Management

Tailored for WAAM production, the system extracts and filters welding fumes, maintaining clean air inside the enclosure, protecting operators and equipment.

Lighting

Shadow-free, daylight, lighting system, improves visibility during operations and maintenance, promoting precision, and reducing errors.

Surveillance

Cameras monitor the process and equipment status, with a live feed displayed on external screens for real-time access, enhancing safety and quality control.

Automatic Door

Automatic locking to prevent unauthorized access, emergency stop buttons and safety interlocks, all centrally controlled for coordinated safety management.

Machine HMI

Centralized control of machine functions, like fume extraction, lighting, door, and process monitoring. The intuitive design allows smooth operations and quick adjustments.

Load & Unload Linear Track

A linear track system simplifies the loading and unloading of components, minimizing downtime and maximizing productivity.

CARACOL

Enclosure

Footprint [m ft]	4.2 x 5.1 x 4.3 13.8 x 16.7 x 14.1
Build Envelope [m ft]	2.5 x 2.0 x 2.0 8.2 x 6.6 x 6.6
Robust Structure	Designed for demanding WAAM process, guarantees durability and reliability thanks to high-grade materials used
UV Resistance	Protects from radiation from welding processes, providing enhanced safety for operations thanks to UV-resistant panels
Assembly/Dismantling & Logistics	Efficient & easy set up, transportable dismantled in containers for quick deployment
Wire Feedstock	Ready-to-use material storage up to 750 kg (1653 lbs)

Sensors

Both models developed by Caracol have been developed with a core set of sensors to monitor key aspects of the process.

Vipra AM's sensors offer real-time monitoring of key parameters, including layer geometry (such as layer height and width) through laser scanning and welding cameras, thermal development around the weld pool using thermal cameras and pyrometers, and the gas flow of the shielding system. This continuous data collection ensures precise tracking of the build process and consistency across every layer.

VIPRA AM

Robotics

Caracol equipped Vipra AM with 9 axes with the industrial anthropomorphous robotic arm and positioner kinematics, to maximize flexibility and 3D print parts with complex geometries.

Caracol works with multi-axis and high dexterity systems like robotic arms as they are the only possibility to match complex building strategies like non-planar slicing, multi-angle welding, on-part features and overhangs.

CARACOL





VIPRAAM

CARACOL

Materials

3D printing metal wires for industrial application

VIPRA AM

Caracol works with its materials partners daily to identify and qualify the best metal alloys for its process. This includes high-performance alloys, tested to ensure efficient production, superior technical properties, and the minimization of costs and waste.

Caracol's Vipra AM platforms are made to process a broad range of materials, thoroughly tested, and qualified for direct, continuous printing.

The **MATERIAL LAB** constantly works to expand the range of materials, selecting new alloys and studying mechanical, thermal, and chemical properties of printed parts, to provide the best options on the market for our clients' applications and guarantee reliable and repeatable production.

CARACOL



ER100S-G Steel

High-quality carbon steel, strong and ductile. Reliable for general fabrication, construction, repair work, and sectors that demand durable and efficient materials.

APPLICATIONS

- **CONSTRUCTION:** Structural steel frameworks, beams, joints.
- **AUTOMOTIVE:** Critical vehicle components, repair.
- **HEAVY EQUIPMENT:** Parts manufacturing, maintenance.

FEATURES

- **BALANCED STRENGTH:** Load-bearing and structural applications.
 - **SUPERIOR DUCTILITY:** Flexibility and impact resistance, for durable parts.
 - **VERSATILITY:** In many sectors and applications.
-

SS316L Stainless Steel

A durable austenitic stainless steel with excellent corrosion resistance, especially in chloride-rich environments. Resists to acids and solvents (e.g., marine, water treatment, chemical).

APPLICATIONS

- **MARINE:** Propellers, hull fittings, and structural parts.
- **OIL & GAS:** Pipelines, flanges, and valves (corrosion & pressure resistant).
- **CHEMICAL:** Tanks, reactors, and piping systems.

FEATURES

- **CORROSION RESISTANCE:** Outstanding against rust and aggressive environments like saltwater and harsh chemicals.
 - **HIGH DURABILITY:** Retains strength and toughness in time.
 - **EXCELLENT FORMABILITY AND WELDABILITY:** Ideal for intricate and complex part designs.
-

SS17-4 PH Stainless Steel

Precipitation-hardening stainless steel that combines high strength and hardness with good corrosion resistance. Suitable parts with high mechanical performance.

APPLICATIONS

- **AEROSPACE:** High-stress parts like landing gear, turbine blades, brackets.
- **CHEMICALS:** Valves, pumps, and fittings with high pressure and corrosion.
- **NUCLEAR:** Critical parts like control rods and fasteners.
- **GENERAL ENGINEERING:** Shafts, gears, and high-performance parts.

FEATURES

- **HIGH STRENGTH AND HARDNESS:** Great mechanical properties.
- **GOOD CORROSION RESISTANCE:** Resists to cracking in chloride environment.
- **HEAT TREATABLE:** Tailoring properties for specific applications.
- **VERSATILE:** Can be age hardened to maximize the desired property.

Materials

SS410 NiMo Stainless Steel

A martensitic stainless-steel alloy with nickel and molybdenum that enhances strength and toughness. Ideal for part with corrosion resistance and wear resistance.

APPLICATIONS

- **OIL & GAS:** Pump shafts, valves, and downhole tools.
- **AUTOMOTIVE:** Gears and shafts.
- **INDUSTRIAL MACHINERY:** Cutting tools, bearings, and components with frequent wear.

FEATURES

- **CORROSION RESISTANCE:** Exposure to water, chemicals, and mild acids.
 - **HIGH STRENGTH AND TOUGHNESS:** Withstands mechanical stress and impact.
 - **WEAR RESISTANCE:** For frequent use and friction.
 - **MACHINABILITY:** Easily machined and finished to high precision standards.
-

AlMg6Zr Aluminum-magnesium Alloy

A non-heat-treatable aluminium-magnesium alloy from the 5000 series. The addition of zirconium refines the grain structure, improving the alloy's thermal stability and resistance to recrystallization. It is engineered for high-performance structural applications and renowned for its excellent corrosion resistance, high mechanical strength, and weldability, this alloy is ideal for applications requiring long-term durability in harsh environments.

APPLICATIONS

- **AEROSPACE:** Structural panels, frames, tanks
- **MARINE:** Components that required high corrosion resistance in saltwater environment
- **AUTOMOTIVE AND TRANSPORT EQUIPMENT:** body panels, tanks and chassis where corrosion resistance and weight reduction are priorities.

FEATURES

- **HIGH CORROSION RESISTANCE:** excellent resistance to seawater, industrial and atmospheric corrosion
- **THERMAL STABILITY:** Maintains strength at low and high temperature
- **GOOD WELDABILITY:** easy to weld and suitable for machining operations

Al2319 Aluminum Alloy

High strength material, well suited for aerospace components that operate at elevated temperatures. Known for its good mechanical properties after heat treatment.

APPLICATIONS

- **AEROSPACE:** Structural parts like fuselage parts, frames, and fuel tanks.
- **AUTOMOTIVE:** Suspension components, and chassis.
- **ENERGY:** Large storage tanks.

FEATURES

- **CORROSION RESISTANCE:** Excellent in seawater and corrosive environments.
 - **HIGH MECHANICAL STRENGTH:** High-stress applications.
 - **GOOD WEAR RESISTANCE:** For components exposed to friction and wear.
-

Inconel 625 Nickel-based superalloy

A nickel-based superalloy with exceptional strength, fatigue and corrosion resistance, and in a wide range of temperatures.

APPLICATIONS

- **AEROSPACE:** Exhaust ducts, turbine blades, and engine parts.
- **MARINE:** Propellers, valves, and seawater-facing parts.
- **CHEMICAL:** Heat exchangers, reactors, and piping systems.
- **POWER GENERATION:** Turbine blades and heat shields.

FEATURES

- **HIGH STRENGTH AND FATIGUE RESISTANCE:** For high-stress, high-temp applications.
- **CORROSION RESISTANCE:** Resists oxidation and corrosion.
- **THERMAL STABILITY:** Resists high temp oxidation up to 982 °C/1800 F.
- **VERSATILE USE:** Applicable in various sectors requiring durability and resilience.

Materials

Invar 36 Iron-nickel Alloy

An iron-nickel alloy known for its very low coefficient thermal expansion, making it ideal for precision instruments and applications requiring dimensional stability over a wide range of temperatures.

APPLICATIONS

- **AEROSPACE:** Tooling and fixtures in composite part production.
- **TOOLING:** Precision molds, dies, and other tools.
- **CRYOGENIC APPLICATIONS:** storage tanks and piping systems.

FEATURES

- **LOW THERMAL EXPANSION:** Minimizes dimensional changes in thermal cycles.
 - **DIMENSIONAL STABILITY** in varying temperatures.
 - **GOOD TOUGHNESS:** Offers good strength and resistance to stress.
-

CuAl8Ni6 Copper Alloy

A copper-aluminum-nickel alloy known for excellent corrosion resistance, high mechanical strength, and good wear resistance. Ideal for marine and industrial environments with harsh conditions.

APPLICATIONS

- **MARINE:** Propellers and impellers, pumps and valves, offshore pipes.
- **OIL & GAS:** Valve seats, pump impellers, and fittings.
- **INDUSTRIAL MACHINERY:** High-wear parts like bearings, gears, and bushings.
- **POWER AND CHEMICAL:** Blades and screw.

FEATURES

- **CORROSION RESISTANCE:** Excellent in seawater and corrosive environments.
- **HIGH MECHANICAL STRENGTH:** High-stress applications.
- **GOOD WEAR RESISTANCE:** For components exposed to friction and wear.
- **HIGH CAVITATION RESISTANCE.**

From applications to technology

Additive manufacturing at the service of diverse industries

Caracol developed its platforms to expand the potential of additive manufacturing to large, complex, industrial applications. After years of 3D printing parts and components alongside industry leaders, the application-first approach is part of the company's DNA and drives technological innovation.

THE INDUSTRIES WE WORK IN:

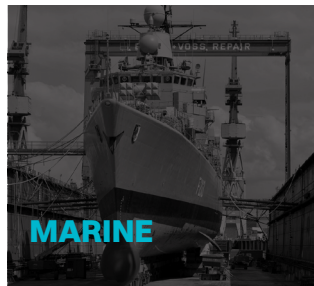
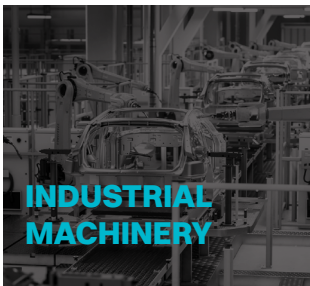

Our case studies

VIPRA AM

AEROSPACE

AUTOCLAVE CURE TOOLS

With Vipra AM, Caracol manufactured a high-precision autoclave cure tool, specifically a stringer mold which is used in the production of stiffened composite panels for aircraft fuselage sections. The part was produced in Invar 36, a material widely recognized in the aerospace industry for its near-zero thermal expansion and dimensional stability in high-temperature environments.

BENEFITS

- **LEAD TIME:** WAAM enables the rapid production of large, complex tools.
- **PART DURABILITY:** using materials such as Invar 36 ensures that the molds remain dimensionally stable during the high-temperature autoclave process, preventing warping and maintaining the precise tolerances of the composite materials.
- **LOW COEFFICIENT OF THERMAL EXPANSION (CTE):** Invar 36 maintains dimensional stability at temperature up to 280 °C.
- **MECHANICAL PROPERTIES:** The alloy's strength and resistance to fatigue make it well-suited for repeated cycles of heating and cooling, as experienced in autoclave curing.

MANUFACTURING SET UP

SYSTEM	Vipra XP
MATERIAL	Invar 36
POST-PROCESSING	CNC
DEPOSITION RATE [kg/h]	5
WEIGHT [kg]	70
DIMENSIONS [mm]	550 x 350 x 120
PRINT TIME [hr]	14

CARACOL



MARINE

PROPELLER

Vipra AM is ideal for the production of parts for the shipbuilding industry such as boat propellers. This part was made with CuAl8Ni6 (Copper-Aluminum-Nickel Alloy), a material well-known for its outstanding corrosion resistance, strength, and durability in seawater environments. This alloy is highly favored for marine propellers due to its excellent resistance to corrosion, cavitation, and biofouling, making it ideal for applications that operate in aggressive saltwater conditions.

BENEFITS

- **CUSTOM GEOMETRIES:** WAAM allows to produce customized propellers with intricate geometries.
- **SHORT LEAD TIMES:** rapid production of parts on-demand.
- **MATERIAL WASTE REDUCTION:** compared to traditional casting and machining methods.
- **CORROSION RESISTANCE:** CuAl8Ni6 is highly resistant to corrosion, especially in marine environments (saltwater and brackish waters) ensuring long service life.
- **HIGH STRENGTH AND TOUGHNESS:** the alloy's mechanical properties allow it to withstand the stresses encountered in high-speed marine propeller operations.
- **RESISTANCE TO CAVITATION:** CuAl8Ni6 performs exceptionally well under cavitation and erosion, reducing material degradation over time and ensuring optimal propeller performance.

MANUFACTURING SET UP

SYSTEM	Vipra XP
MATERIAL	CuAl8Ni6
POST-PROCESSING	Shot peened
DEPOSITION RATE [kg/h]	4.6
WEIGHT [kg]	45
DIMENSIONS [mm]	700 x 700 x 350
PRINT TIME [hr]	10.5



Our case studies

VIPRA AM

OIL & GAS

MULTI-MATERIAL NECK FLANGE

We produced multi-material neck flanges using Vipra AM, leveraging the system's flexibility to manufacture with two materials: Inconel 625 for its strength and corrosion resistance and ER70S Steel for its versatility and durability. This approach delivers a high-performance solution designed to withstand the extreme pressures, temperatures, and corrosive environments found in the Oil & Gas industry.

BENEFITS

- **MULTI-MATERIAL PRODUCTION:** easy integration of two materials to optimize part performance, functionalities and costs.
- **OPTIMIZED PART:** Inconel 625 was used in high-stress, high-corrosion regions, and ER70S steel for less critical areas, to maintain a material-efficient design while guaranteeing part performance.
- **INCONEL 625:** ideal for components exposed to severe environments, it provides exceptional fatigue and stress-corrosion cracking resistance.
- **ER100:** it offers good mechanical properties and, when used in combination with Inconel 625, it adds cost-efficiency without compromising on performance.

MANUFACTURING SET UP

SYSTEM	Vipra XP
MATERIAL	Inconel625 + ER100
POST-PROCESSING	CNC
DEPOSITION RATE [kg/h]	5
WEIGHT [kg]	14
DIMENSIONS [mm]	270 x 270 x 110
PRINT TIME [hr]	3

CARACOL



INDUSTRIAL MACHINERY

CONVEYOR SCREW

Vipra AM is a great solution to produce conveyor screws or spiral drills, for industrial machinery applications. 316 Stainless Steel was used as the material is widely regarded for its excellent corrosion resistance, durability, and strength, making it the ideal choice for demanding industrial environments where heavy loads and abrasive materials are present.

BENEFITS

- **CUSTOMIZATION:** custom conveyor screws can be designed and printed to ensure the precision and strength needed for optimal performance.
- **REDUCED MATERIAL WASTE**
- **SHORTER LEAD TIMES:** compared to traditional machining or casting methods.
- **CORROSION RESISTANCE:** 316 Stainless Steel is highly resistant to corrosion, particularly in environments where exposure to acids, chemicals, and saltwater is frequent, ensuring a long service life in harsh industrial conditions.
- **STRENGTH AND DURABILITY:** The alloy's mechanical properties, including high tensile strength, make it capable of handling the rigorous demands of conveyor systems, which often involve abrasive materials and heavy loads.
- **EASE OF FABRICATION:** 316 Stainless Steel is easily deposited allowing to produce complex spiral geometries required in conveyor screws.

MANUFACTURING SET UP

SYSTEM	Vipra XP
MATERIAL	SS 316L
POST-PROCESSING	Shot peened
DEPOSITION RATE [kg/h]	4.9
WEIGHT [kg]	85
DIMENSIONS [mm]	1000 x 350 x 350
PRINT TIME [hr]	17.5



Our case studies

OIL & GAS

WAAM-PRODUCED SAMPLING VALVE

This sampling valve body, designed to operate at 5 bar line pressure, is traditionally manufactured through casting - a process that typically takes around 60 days, from mold preparation to pouring and finishing. In contrast, leveraging Vipra AM, the same part was produced and delivered in less than 48 hours. The valve was produced by JOME Engineering LLC.

BENEFITS

- LOWER EMISSIONS, as energy intensive furnaces for casting were not required.
- REDUCED MACHINING TIME, thanks to improved near-net-shape build quality.
- SUSTAINABLE MANUFACTURING, minimizing material waste.

MANUFACTURING SET UP

SYSTEM	Vipra XP
MATERIAL	SS 316L
POST-PROCESSING	Heat treatment and machining
DEPOSITION RATE [kg/h]	2,7
WEIGHT [kg]	20,5
DIMENSIONS [mm]	220 x 310 x 220
PRINT TIME [hr]	7,5



Service

At your service, from
installation to production

At Caracol we want to ensure we provide best-in-class solutions to optimize your production efficiency.

Our team oversees the installation, layout design, and start-up of our LFAM platforms, providing training to manage the technology correctly and safely, teaching you how to perfect your skills printing with LFAM, applications know-how, and assistance with maintenance, spare parts, and remote support.

All with the aim of ensuring your successful manufacturing of parts and production continuity.



SERVICE PACKAGES

Learn about the different options you can access; from the Light to the Continuity packages, you can choose a support customized to your know-how and needs. Includes: WARRANTY, MAINTENANCE, SPARE PARTS, HOTLINE, TRAINING, and more.



TRAINING PROGRAMS

Become an LFAM expert with our tailored programs made to help you advance your skills from CAD to Slicing, to operating your machine and 3D Printing to Post-Processing.

VIPRAAM

CARACOL

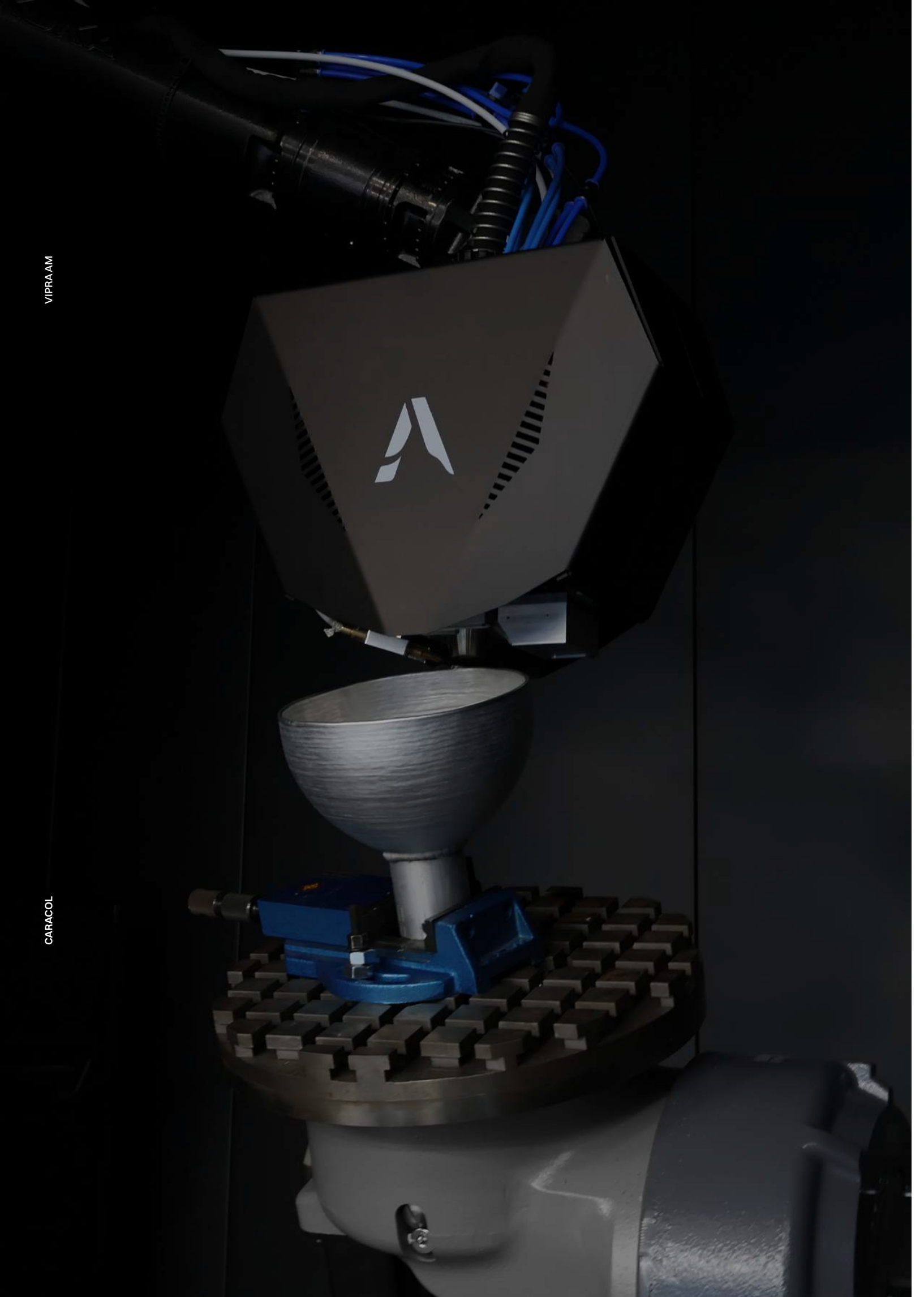

Copyright 2025 Caracol S.r.l.

Via Marisa Bellisario, 6C

Barlassina (MB) | Italia

General Requests: info@caracol-am.com

Commercial Requests: bd@caracol-am.com

This document and its parts cannot be duplicated or shared with third parties without the explicit consent by Caracol S.r.l. This document's conformity has been verified regarding the described hardware and software.

Minimal differences and variations in technology cannot be excluded with the utmost certainty.

All information in this document has been checked, any edits or technical improvements and variations to the technology described will be published in following versions.

Version: VIPRA AM - 2510

caracol-am.com

VIPRA AM - 2510

CARACOL